

## M921DB LED Module

**Edge lit solution for 80-200mm depth single sided light box  
and 140-400mm depth double sided light box**



### ADVANTAGES

- 5 years warranty\*
- Highly efficient 3535 flip eutectic SMD LED
- Superior luminous efficiency—105lm/W (white), 126lm/module
- Special lens to achieve optimal light distribution to match applications
- Constant current driving technology guarantees stable illumination performance
- Casing by SHELL adopted flame retarded engineering plastic
- Good heat sink performance by use of aluminium base PCB
- IP65 over-moulded design suitable for outdoor sign applications
- UL, CE, RoHS compliant

\* 5 years or 22,000 hours, whichever comes first

\* Working within operating temperature

### LIGHT DISTRIBUTION

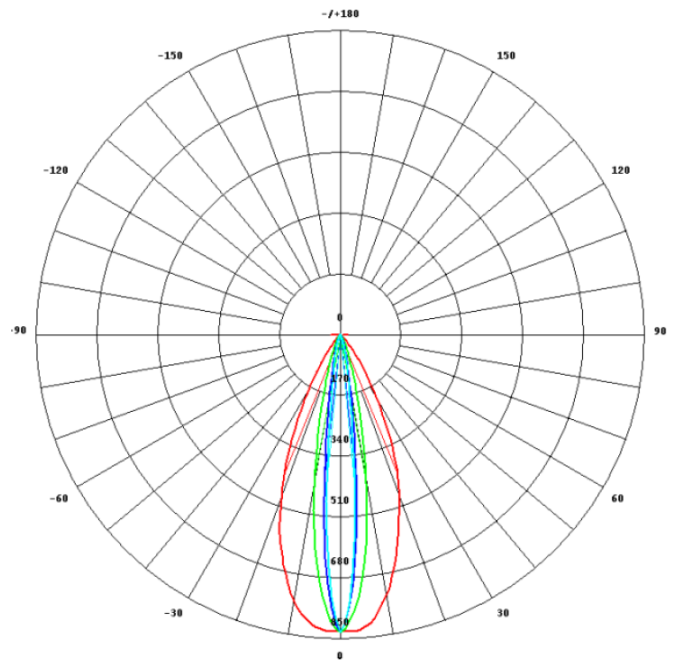

### INSTALLATION

- Max. 25 modules per string
- Easy installation with 3M self-adhesive tape, permanent screw fixed
- Can cut every single module

**ASTECH (a Division of the Albert Smith Group)**

59 Taylor St Bulimba QLD 4171, Ph. 07 3395 9888 Fx. 07 3891 0713

Email: [enquires@asgroup.com.au](mailto:enquires@asgroup.com.au) Web: [www.albertsmithgroup.com.au](http://www.albertsmithgroup.com.au)

ABN. 42345973910

## M921DB LED Module

**Edge lit solution for 80-200mm depth single sided light box  
and 140-400mm depth double sided light box**

### PRODUCT OPTIONS

P/N	LED Colour	Colour Temperature (K) Wavelength (nm)	Luminous Flux (lm/module)	CRI	Luminous Efficiency (lm/W)	Working Voltage (V DC)	Working Current (mA/module)	Power (W/module)
M921DB	Natural	7000	126	≥75	105	12	100	1.2

### OTHERS

P/N	Colour Option	Standard Cascading Qty (pcs)	Max Cascading Per String		Single Module Weight (g)	Operating Temperature (°C)	Storage Temperature (°C)	Ingression Protection Grading
			Single End	Double End				
M921DB	Natural white	25	25	N/A	34	-25 ~ +60	-25 ~ +70	IP65

### PRODUCT PROFILE

unit: mm [in]

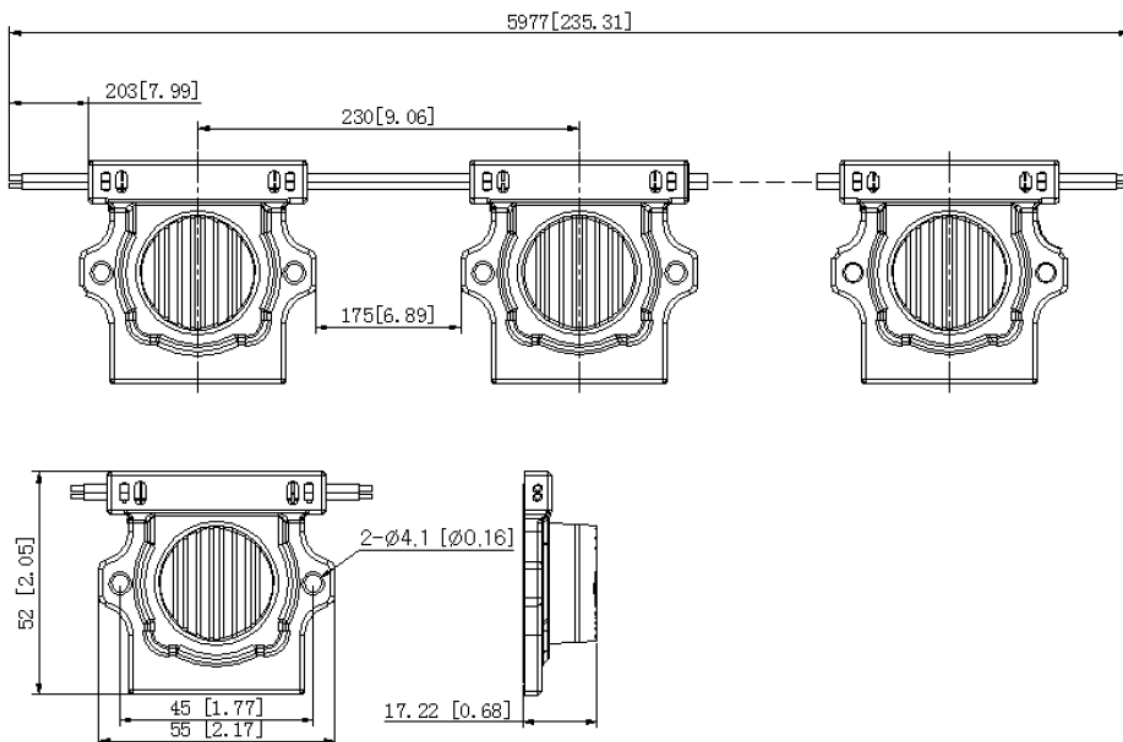

**ASTECH (a Division of the Albert Smith Group)**

59 Taylor St Bulimba QLD 4171, Ph. 07 3395 9888 Fx. 07 3891 0713

Email: [enquires@asgroup.com.au](mailto:enquires@asgroup.com.au) Web: [www.albertsmithgroup.com.au](http://www.albertsmithgroup.com.au)

ABN. 42345973910